



Classic Conveyor Idlers

Our Company

Since 2001 Fenner Dunlop - Classic Conveyor based in Blairsville, PA, has supplied high quality idlers and components to the bulk material handling industry. Fenner Dunlop - Classic Conveyor manufactures a complete range of CEMA class idlers from CEMA B to CEMA F and SERIES 60. Our idlers have been supplied for installations in underground mining, pipe conveyors, long-high capacity overland conveyors, ship-loading terminals and in-plant conveyors.

Fenner Dunlop - Classic Conveyor has introduced products which include **conveyor belt weigh scales, composite idler rolls, aluminum idler rollers, low weight steel idler rollers and conveyor pulleys**. Fenner Dunlop - Classic Conveyor has established a network of distributors and agents which ensures supply and after-sales service for all of our products.

In addition to our idlers Fenner Dunlop - Classic Conveyor manufactures high quality products including **belt scales, belt cleaners, drives and conveyor structure** used in the mining, quarrying, agricultural, ship loading, utility, material and bulk solids handling industries.

Fenner Dunlop - Classic Conveyor has successfully supplied idlers for large conveyor systems in North and South America. Our employees pride themselves on carrying out the high demands of export planning, production and delivery.

Our idlers utilize centrifugally sealed rollers, which have been used successfully throughout the world since the 1960s. Fenner Dunlop - Classic Conveyor idler ratings vary from CEMA B to CEMA F in addition to our own rating, SERIES 60, which exceeds all the CEMA ratings.

Fenner Dunlop - Classic Conveyor utilizes the latest design and manufacturing technology together with on-going programs that ensure the highest quality components. This includes AUTOCAD design facilities, laser alignment and measuring equipment. R&D consists of the monitoring of selected underground and surface installations over a number of years. In-house test rigs and specialized monitoring equipment are used to improve the quality of our products. Manufacturing tolerances are continually monitored and new manufacturing techniques consistent with the latest technology are implemented. An example of this program has been the high accuracy of our conveyor bases and supporting structures which results in excellent belt tracking and the reduction of belt deflection loads.

Fenner Dunlop - Classic Conveyor Idlers

Fenner Dunlop - Classic Conveyor manufactures idlers and conveyor structure in-house. Facilities include machine and press shops, dedicated painting facilities, robotic welding and a state-of-the-art steel fabrication plant.

The following idler roll types are manufactured:

- steel
- rubber disc impact and return
- aluminum
- HDPE or polyurethane sleeved
- HDPE

PRODUCTS: Idlers (Steel Rollers)

Fenner Dunlop - Classic Conveyor idlers utilize centrifugal self-cleaning seals, which ensure that bearings reach their designed life. Grease-free sealing elements result in much lower friction values than conventional designs.

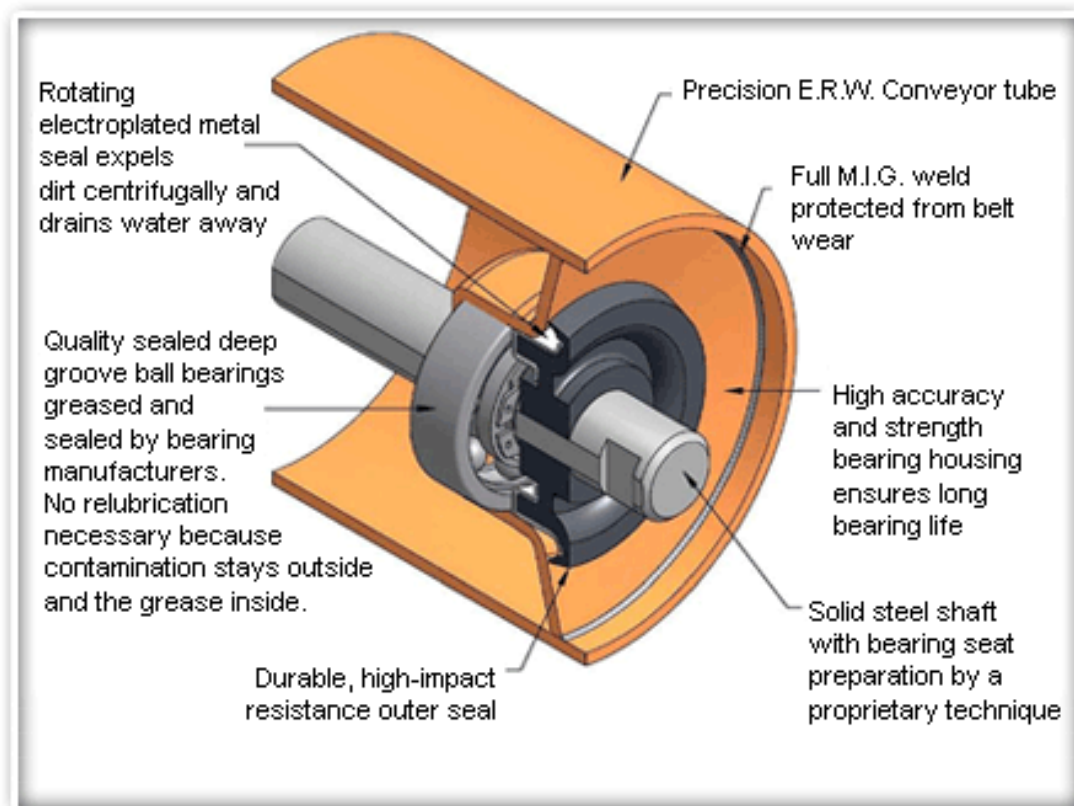

SPECIFICATIONS

Bearings: Deep groove double sealed or shielded bearings of tolerance class C3 and C4 are used. This allows for a larger amount of angular misalignment at the bearing than other bearing designs and classes.

Steel Tube: Only high quality tube specially manufactured for conveyor rollers is used and conforms to ASTM A-513-07. Shell ends are machined to prevent belt wear.

Steel Shaft: Manufactured from steel which complies with the requirements for grade ASTM A108-07 (CR1018). The shaft diameter tolerance is as recommended by bearing manufacturers and ensures a js6 fit. Shaft end slots are machined to customer standards.

Hollow Shaft: Stepped light weight hollow steel shafts equivalent in strength and rigidity to solid shafts are available on request.

Bearing Housing: Manufactured from deep drawing material ASTM A-1011-08DSB. Housings are pressed and MIG-welded to the inside of the tube.

Corrosion Protection: External coat of gray powder coated paint unless otherwise specified.

Circular Movement Tolerance (TIR): TIR does not exceed 0.5 mm measured at a distance of 25 mm from the roller end face. Actual TIR values are less and can be verified by reference to historical data.

Idler Running Friction: Fenner Dunlop - Classic Conveyor Idlers have frictionless seals.

Idler drag is due to bearings only and is therefore easy to predict. Drag is dependent on factors such as loading, rpm, bearing type, characteristics and temperature. Consult Classic Conveyor for friction values.

SEAL DESIGN

Primary Sealing

The success of the primary sealing area lies in the fact that dirt which enters is ALLOWED TO ESCAPE. The metal seal collects dirt and flings it outward in a radial motion due to centrifugal force (3-9 times gravitational).

Secondary Sealing

Dirt which enters secondary sealing area is again propelled outwards by centrifugal force. All sealing surfaces are clean and free from contact and do not require packing with grease. The sealing arrangement is so designed that water drains out of the seal when the idler is stationary.

Most secondary seals on the market are of the labyrinth type and centrifugal force actually helps keep dirt in the sealing area where it can work its way back to the bearing.

Bearing Sealing

Greased for life bearings complete with seals on both sides are used. The bearing seals form the final barrier against dirt ingress, especially rust particles which are formed due to condensation inside the shell tube.

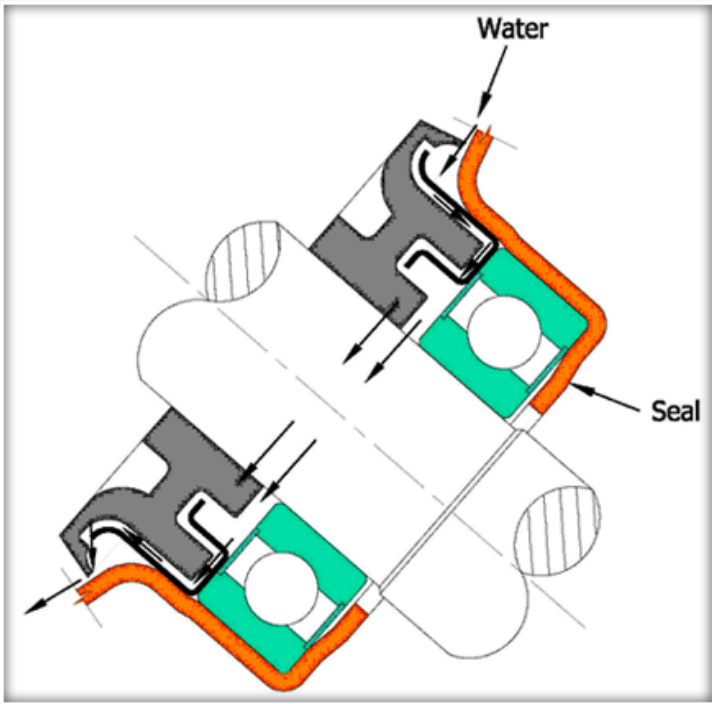
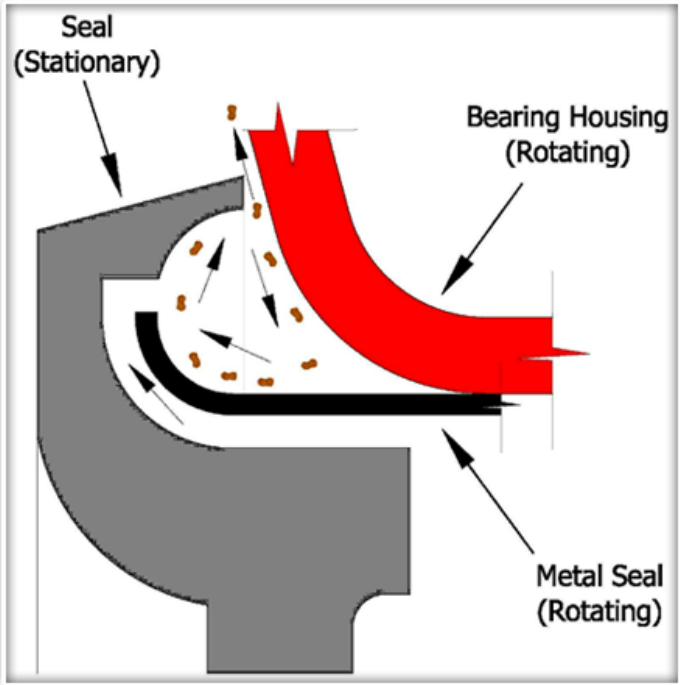



Standard Classic Conveyor idler rolls used in Shotblast Booth still turning freely after 1 year operation

PRODUCTS: Idlers (Impact & Rubber Disc Rollers)

Impact and rubber disc rolls consist of steel reinforced rubber impact discs press fitted onto a conventional steel roller body. Each rubber disc is positively located and there is no possibility of rubbers moving due to impact loads. Spacers and end-stops are not required. Apart from the rubber discs, the same components and seals are used for the steel rollers.

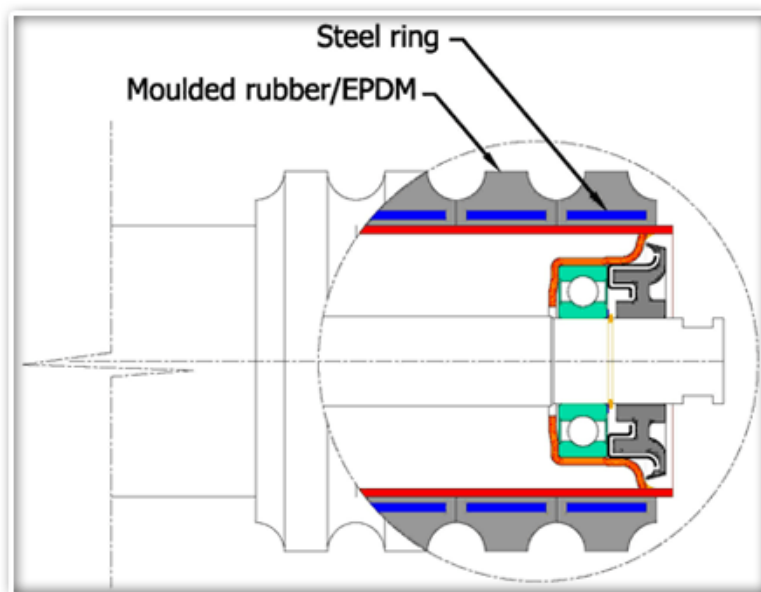

PROJECTS: Henderson

Project: Henderson

Location: Colorado, USA

Commissioned: 1999

System Description:

The Henderson Mine is located approximately 50 miles west of Denver, Colorado, USA. A material handling project was completed in the fall of 1999 to replace the rail system, which transported molybdenum ore 24km from the mine to the mill using a three flight conveyor system.

The first conveyor (PC1) is a 1km high lift conveyor, which transports the ore from an underground crushing station to the end of the existing tail tunnel.

The second conveyor (PC2) is 17km in length and utilizes the existing rail tunnel to transport the ore from the mine, which is the East Side of the continental divide, to the mill located on the West Side.

The third conveyor (PC3) is 6.3km long, takes ore from the tunnel portal to the mill through a series of 9 horizontal and 9 vertical curves and inclines up to 15 degrees.

The project applied advance conveyor design to tackle the installation of the system in an operating mine and achieved the highest possible level of reliability.

Significant savings were obtained due to the reduced idler roll running friction:

1. Belts with a thickness 1 class below the original specification could be selected - the achieved savings was greater than the cost of the conveyor idler and structure.
2. Reduced capital costs for the drives and pulleys.
3. Power savings greater than \$ 400,000 per annum at 1999 prices

PROJECTS: Escondida

Project: Escondida

Location: Chile

Technical Data:

Material Transported:	Copper Ore
Conveyor Lengths:	580m, 3,770m, 3,716m, 1,936m
Capacity:	4,889 MTPH
Belt Speeds:	4.7 - 6.1 m/sec
Required Power:	800 kW - 4,800 kW

Typical power consumption costs per idler roll are US\$20 per annum. This represents a 10% savings in annual power consumption costs over other rolls.